

DATA SHEET

Si-30

Piston Pump

Sauermann® part#: SI30CE02UN23



Versatile technology

The high performance Si-30 is suitable for air-conditioning units up to 20 kW. The piston technology is specifically designed for removing condensates from air conditioning systems. The Si-30 is fully reliable, in any kind of environment. Its operating sound level will remain silent whatever the volume of condensates.

Benefits



Patented technology

- Increased performance: Only one pump, for air conditioning unit up to 20 kW.
- High resistance to pollution created by general environment. Capable of discharging small particles.
- Proven Reliability.
- The Drain Safe Device retains prime and prolongs the pump life.



Silent

- Quiet in operation: 20 dBA independently tested.
- The size of the air-conditioning unit and volume of condensates to be removed does not affect the operational sound level of the pump.
- Mounting bracket specifically designed to reduce vibration transmission to the wall / panel or pipework.



Energy saving

- Improved performance and high flow rate reduce operation time and energy consumption.



Easy to install

- Compact design.
- Mounting bracket: allows the pump to be wall mounted or hung from ceilings and pipework.
- Lockable plug-in power cord to avoid unintended disconnection.

Kit contents

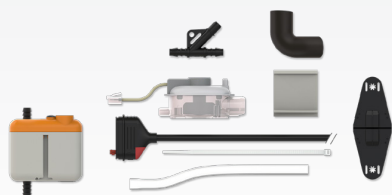

- Piston pump
- Clear PVC tube Ø int. 6 mm – L: 1m, fitted with a "Drain Safe Device" pre-mounted
- Anti-vibration mounting bracket
- 1.5 m lockable plug-in power cable: 2 power wires, 2 safety switch wires
- 6 tie wraps, 2.5 x 100 mm
- Detection unit (SI2958, 1.5 m cable)
- Detection unit installation kit:
 - Rubber elbow 90° Ø int.15 x L 60 mm
 - Vent tube Ø int 4 x L 75 mm
 - Mounting rail
 - Adhesive

Technical specification



Max. flow rate	20 l/h
Max. suction head	3 m
Max. discharge head	10 m (flow rate = 4 l/h)
Max. pressure	14 m (flow rate = 0 l/h)
Sound level at 1m According to EN ISO 3744 (Measured at LNE lab, pump operating with water, out of application)	20 dBA
Mains supply	230 V~ 50/60 Hz - 14 W
Insulation class	□ (double insulation)
Detection levels	ON: 16 mm; OFF: 11 mm; Safety: 19 mm
Safety switch	NC 8 A resistive – 250 V
Thermal protection (overheating)	115 °C (auto-reset)
Max. condensate temperature	35 °C
Operating conditions	100% - Continuous duty
Protection	IP20
Safety standards	CE & EAC
RoHS directive	Compliant
WEEE directive	Compliant
Packaging	0.48 kg – L 135 x l 135 x H 90 mm
Masterpack	20 pieces

Applications

For use with any air-conditioning units, up to 20 kW:

- Wall mounted
- Ducted
- Ceiling suspended
- Fan-coils

Accessories

Name	Ref
 Clear PVC hose Ø int. 6 mm (1/4")	ACC00909 (5 m) ACC00910 (50 m)
 5 Self-sealing fittings for hose Ø int. 6 mm (1/4")	ACC00919

Dimensions

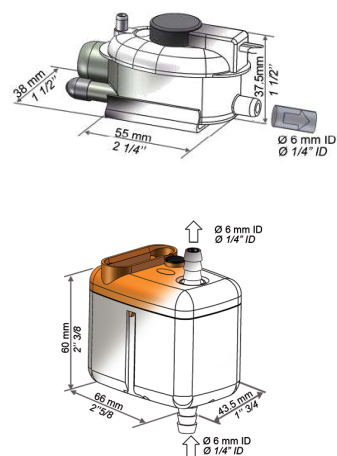

Actual flow rates (l/h)

Suction head (A)	Discharge head (B)	Total hose length using (Ø int. 6 mm, 1/4") – (C)			
		5 m	10 m	20 m	30 m
0 m	0 m	20	19	18	17
	2 m	16	15	14	13.5
	4 m	11.5	11	10.5	10
	6 m		8.5	7.5	6.5
	8 m		6	5	4
	10 m		4	3.5	2.5
1 m	0 m	14	13	12	11
	2 m	11	10	9	8
	4 m	7.5	7	6	5
2 m	0 m		4.5	4	
	0 m	11	10	9	8
	2 m	9	8	7	6
3 m	4 m		5.5	5	4.5
	0 m	10.5	9	8	7
	2 m	8	7	6	5
	4 m		5	4	

